

Achieving Optimal Read Range - It's all in the Frequency

Frequency

The relationship between a card and reader can be seen as analogous to tuning your AM radio to a radio station's frequency in order to receive the best possible reception. Both the card and reader are designed to operate at an ideal frequency to facilitate the best possible read range. While most cards are passive devices, when energy from the reader "wakes up" the card, it transmits data back to the reader. As a passive device, it is critical that this data is transferred efficiently. If the reader and card are off frequency, the card needs to be brought closer to the reader for communication. In extreme cases, the mismatch of frequency is so great that a user must touch his card to the reader's surface to communicate. On the other hand, when a card is tuned close to the reader's frequency, it will achieve a longer read range.

While ISO standards designate 13.56 MHz as the carrier frequency for high frequency readers, the resonant frequency can vary based on the chip design and use case. For example, when using a MIFARE card, a manufacturer recommends that the resonant frequency range (it's most efficient energy transfer) should be between 14.5 MHz and 17.5 MHz.

The chart below shows a hypothetical example of a reader tuned to 14.5 MHz (vertical line) and the read range of cards tuned to a resonant frequency range of 13.0 MHz to 17.5 MHz. This reader is designed for peak performance at 14.5 MHz, with performance deteriorating quickly outside of this peak. At 13.0 MHz, the read range deteriorates significantly, requiring a rub on the reader surface.

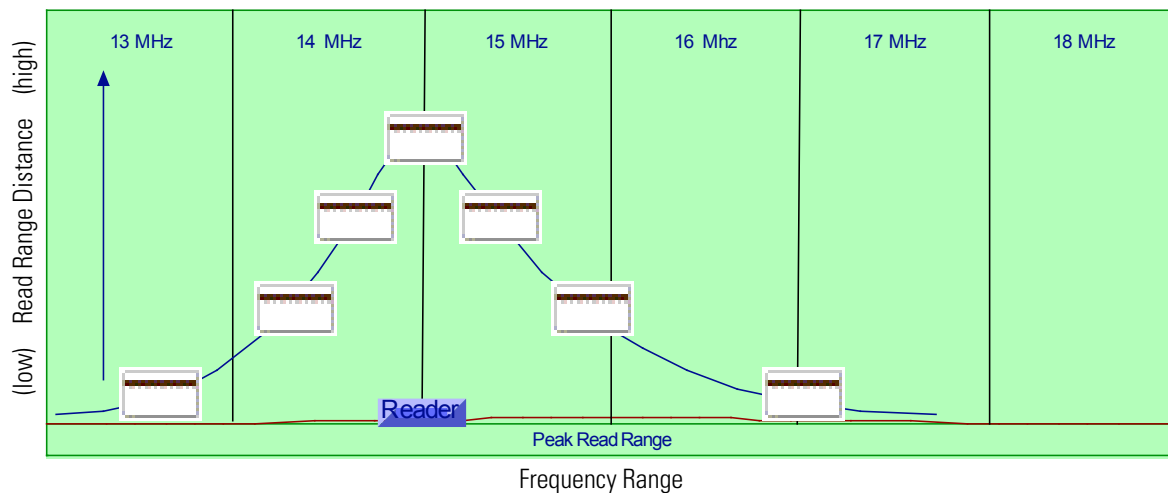

Tolerance

Another variable to consider is the tolerance of the reader and card. Since there are precise frequencies in both products, it is important to control their manufacturing tolerance range. While tolerances are inevitable in electronics manufacturing, it is critical that they are managed within a tight frequency bandwidth to minimize performance variations. The following chart shows a hypothetical example of manufacturing tolerance of a reader and a range of card frequencies from 14.0 MHz to 18.5 MHz. In this example, the reader can span a larger frequency range without a dramatic change in read range. So even though a card may be tuned at the correct resonant frequency, the reader could be at the far end of the tolerance range, reducing read range by 20 percent. Outside the reader's tolerance window, the card read range drops off at a much steeper rate.

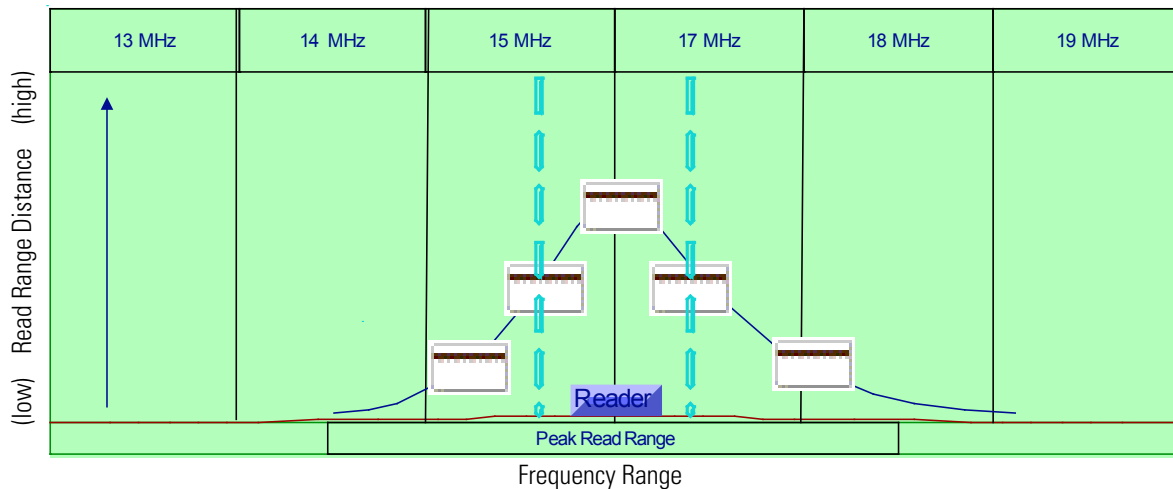

If cards are purchased with a resonant frequency of 14.0 MHz, the read range will drop to less than one inch. Purchasing cards and readers together, from the same manufacturer is critical. Guarantee peak performance by extensive testing conducted before introducing a new reader or card.

Verifying Read Range

Have you purchased cards from a different supplier and wondered why the read range is not satisfactory for your customer? Your first thought is your readers have a problem, and you start exchanging readers, but this action does not help. The problem is the cards were not optimized for your readers.

An extreme case of this is revealed with the following example. When used within a transit application, MIFARE cards are usually tuned in the range of 17 MHz to 18 MHz. This frequency range is necessary for their use at a train station, when multiple cards are within the reader's range. However, when multiple cards are within the reader's field, it causes a drop in frequency of all the cards to the optimal performance (frequency) range of the transit reader. When transit card manufacturers have an excess supply of MIFARE cards (tuned to the higher 17 MHz to 18 MHz frequency range), they will repurpose their cards for use in the physical access control market. Because access control readers are intentionally designed to read one card at a time, these higher frequency transit cards can sometimes cause poor read range problems.

The chart below illustrates this extreme case of mismatched physical access readers with transit cards. While this is not typical, and optimal read range performance will vary from reader to reader, it is important to verify read range before installation to avoid problems.

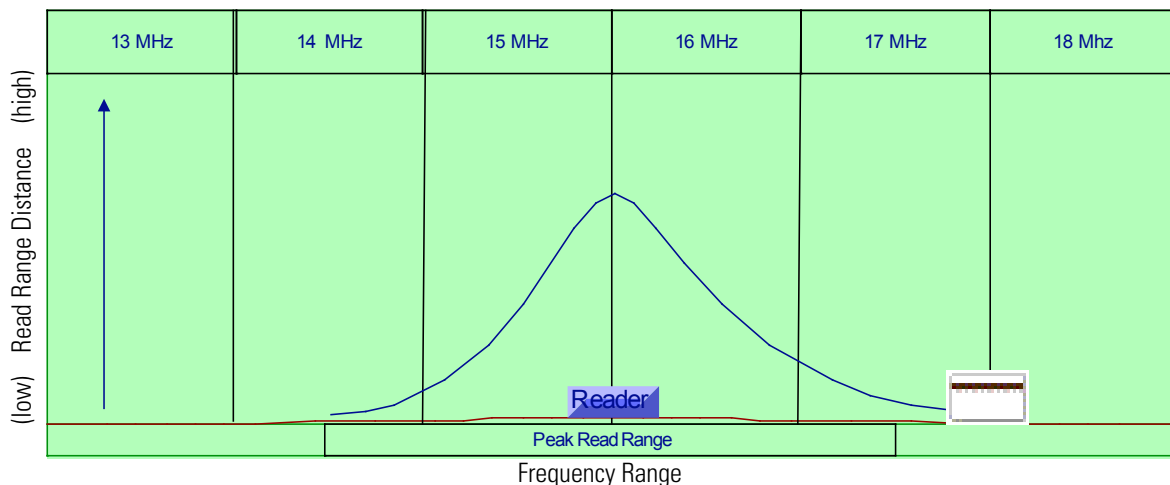

Card Read Range Performance

With the multitude of readers and cards available in the market today, it is important to understand the factors that can affect read range performance. The chart below shows a hypothetical range of readers and cards in the marketplace. Some readers have an excellent read range within a very small frequency range, while others can span a greater frequency range, but sacrifice spectacular read range.

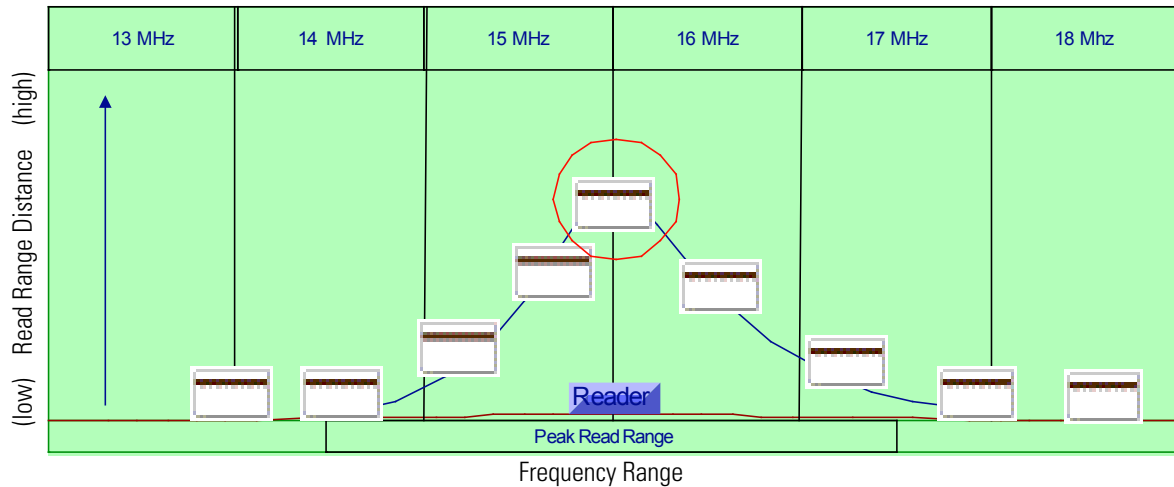

Going back to the earlier AM radio example, the highest reception quality is achieved by matching the frequency of the radio to the frequency of your favorite station. A few notches off, you can hear the station, but it's not clear. The same holds true in the relationship between cards and readers. By matching the frequencies of both, read range will be at its greatest point. Therefore, let the manufacturer match the readers and cards for you. It makes installations more pleasant when it all comes together for you.